

Bradlee Boilers Ltd Fact Sheet

Steam Package Boiler

Document Ref: FSa001

Unit 3 Timmis Road,
Stamermill Industrial Estate,
Lye, Nr Stourbridge,
West Midlands.
DY9 7BJ



Telephone: +44 01384 423859
Fax: +44 01384 895435
E-Mail: Bradleeboilers@bigfoot.com
Website: www.bradleeboilers.com

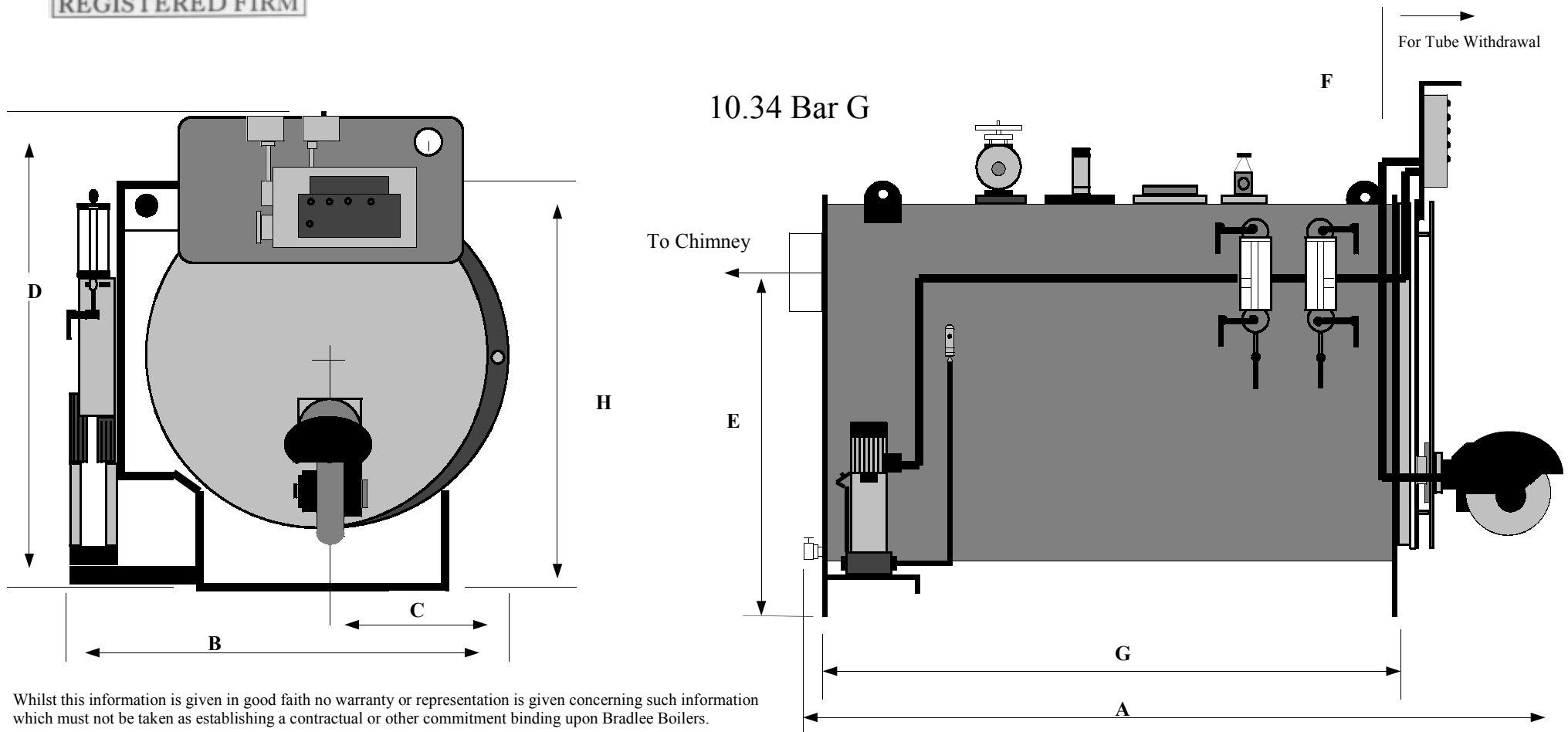

Whilst this information is given in good faith no warranty or representation is given concerning such information which must not be taken as establishing a contractual or other commitment binding upon Bradlee Boilers.

Boiler Model Number		3	7	10	15	22	29	35	43	58	70	87	101	116	145	174	232	290	320	350	380	400	435	
Evaporation	kW	31	62	94	156	213	284	357	427	570	714	853	995	1137	1422	1706	2275	2844	3134	3510	3761	3949	4263	
F.&A. 100oC (212oF)	kg/h	50	100	150	250	340	455	570	680	910	1140	1360	1588	1815	2268	2720	3630	4535	5000	5600	6000	6300	6800	
	lb/h	110	220	330	550	750	1000	1255	1500	2005	2510	3000	3500	4000	5000	6000	8000	10000	11025	12348	13230	13891	14994	
Dimensions (Oil)	A	mm	1690	1809	1809	2159	2274	2464	2664	2664	2726	2826	3121	3171	3225	3734	4049	4404	4628	4722	4722	4722	4722	4722
	(Gas)	A	mm	-	1774	2004	2354	2464	2464	2817	2817	3069	3169	3232	3282	3362	3838	4269	4624	4663	4562	4562	4562	4562
	B	mm	1149	1149	1365	1361	1369	1455	1455	1485	1525	1645	1655	1670	1745	1815	1935	2080	2290	2756	2904	3114	3216	3286
	C	mm	427	427	535	533	537	580	580	595	615	675	675	688	725	760	805	905	1010	1221	1302	1407	1458	1493
	D	mm	1202	1202	1418	1414	1587	1673	1688	1718	1778	1898	2043	2055	2113	2198	2248	2593	2778	3265	3427	3637	3739	3849
	E	mm	830	930	975	1010	1030	1110	1110	1140	1175	1275	1275	1290	1350	1405	1470	1650	1835	2255	2417	2627	2729	2799
	F	mm	1100	1100	1100	1450	1500	1500	1700	1700	1800	1900	2100	2150	2200	2660	2975	3330	3330	3230	3230	3230	3230	3230
	G	mm	1208	1208	1208	1558	1608	1608	1808	1808	1908	2008	2208	2258	2310	2742	3085	3440	3440	3442	3442	3442	3442	3442
	H	mm	1067	1067	1283	1279	1287	1373	1373	1403	1443	1563	1678	1690	1748	1803	1853	2023	2233	2655	2817	3027	3129	3199
Recommended Chimney Dia.	mm	50	75	100	125	125	145	162	180	205	230	255	280	290	305	355	405	440	455	465	480	495	515	
Safety Valve Exhaust Dia	BSP/mm	1"	1"	1"	1"	1"	1"	1"	1"	1.25"	1.25"	1.5"	1.5"	1.5"	2"	2"	80	100	125	125	125	125	150	
Steam Stop Valve Dia.	BSP/mm	0.5"	0.5"	0.75"	0.75"	32	32	40	40	50	50	65	65	65	80	80	100	100	125	125	125	125	125	
Blow Down Valve Dia.	mm	25	25	25	25	25	25	25	25	25	25	25	25	25	25	25	25	25	50	50	50	50	50	
Feed Pump Inlet Dia	mm	25	25	25	25	25	25	25	25	25	25	25	25	25	25	32	32	32	32	32	40	40	40	
Fuel Consumption (Oil)	l/h	3.4	7.2	10.7	17.5	23.9	32.0	40.0	47.7	64.3	80.5	96.3	112.5	128.2	159.8	193.4	258.2	323.4	354.5	394.1	420.5	440.5	478.4	
Fuel Consumption (Gas)	m3/h	-	7.0	10.7	17.2	23.7	32.1	40.0	47.4	64.2	80.5	96.3	112.6	128.4	159.6	193.5	258.6	324.2	354.9	393.5	419.6	439.1	477.7	
Boiler Weight (Empty)	Tonne	0.94	1.08	1.18	1.45	1.55	1.76	1.86	2.04	2.36	2.77	2.99	3.35	3.75	4.47	5.59	7.65	9.08	11.77	13.04	15.06	15.95	16.62	
Boiler Weight - To N.W.L	Tonne	1.25	1.45	1.58	2.03	2.14	2.49	2.64	2.86	3.25	3.93	4.20	4.61	5.22	6.45	7.96	10.98	13.28	18.83	21.51	25.03	26.91	27.51	
Boiler Weight - Full of Water		1.30	1.52	1.66	2.16	2.27	2.64	2.81	3.05	3.46	4.20	4.50	4.93	5.59	6.94	8.59	11.88	14.60	21.03	24.53	28.53	30.71	32.18	

Notes

1. Oil Fuel Consumption based on class D:BS 2869 N.C.V.35863 Kj/l (15422 BTU/lb)
2. Gas Fuel Consumption based on Gas N.C.V.34828 Kj/m3 (935 Btu/Ft3)
3. All Dimensions and weights are approximate only based on Boiler working pressure of 10.34Bar g
4. Fuel consumptions based on boiler working pressure of 10.34Bar g

Bradlee Boilers Ltd
Unit 3 Timmis Road, Stambermill Industrial Estate,
Lye Nr, Stourbridge, West Midlands.
DY9 7BJ

10.34 Bar G